



**PERFORMANCE DATA SHEET
NEMA PREMIUM NR CAN NEMA 12 - 12**

Catalogue #: JMPPS-2

HP	kW	Voltage	S.F. @ 60Hz	EFF.	P.F.	Frame	Design	L.R. Amps
1	0,75	575	1,15	85,5%	0,644	143JM	B	12

60 Hz								
FLA							Code	F.L. RPM
208	230	416	460	480	575	600		
/	/	/	/	/	1,36	/	K	1740

50 Hz								
FLA			S.F. @ 50Hz	Efficiency	Power Factor	Code	F.L. RPM	
190	380	415						
/	/	/	/	/	/	/	/	

Wgt. Lbs	PH	Duty	Insul. Class	Amb.	Elevation	Temp. Rise° C
36	3	Cont.	F	40°C	1000M (3300 Ft)	25

% Efficiency		% Power Factor		Torque		Winding Resist. Ω	Safe Cold Start (Secs)
Full Load:	85,5%	Full Load:	0,64	Full Load Ft/Lbs	3,0		
3/4 Load:	84,2%	3/4 Load:	0,60	Locked Rotor %	300		
1/2 Load:	78,0%	1/2 Load:	0,47	Break Down %	310	19	12

Rotor Inertia Wk2 Lb-Ft2	Max Load Inertia Wk2 Lb-Ft2	Shaft Material	Frame Material	DE Bracket Type	ODE Bracket Type	Enclosure	NEMA Rating	Lead Wire Size
0,04	8,5	Stainless Steel				TEFC	IP69K	16AWG

Ball Bearings		Grease	Mount Type	Orientation	Paint	Sound Pressure @ 3FT	Sound Power
DE	ODE						
6205	6205	Sealed Bearings	Rigid	Horizontal	-	61	70

Inverter Duty. Motor meets MG1 parts 31.4.4.2	Constant Torque Range	Variable Torque Range	Constant HP RPM
	10:1	20:1	2700

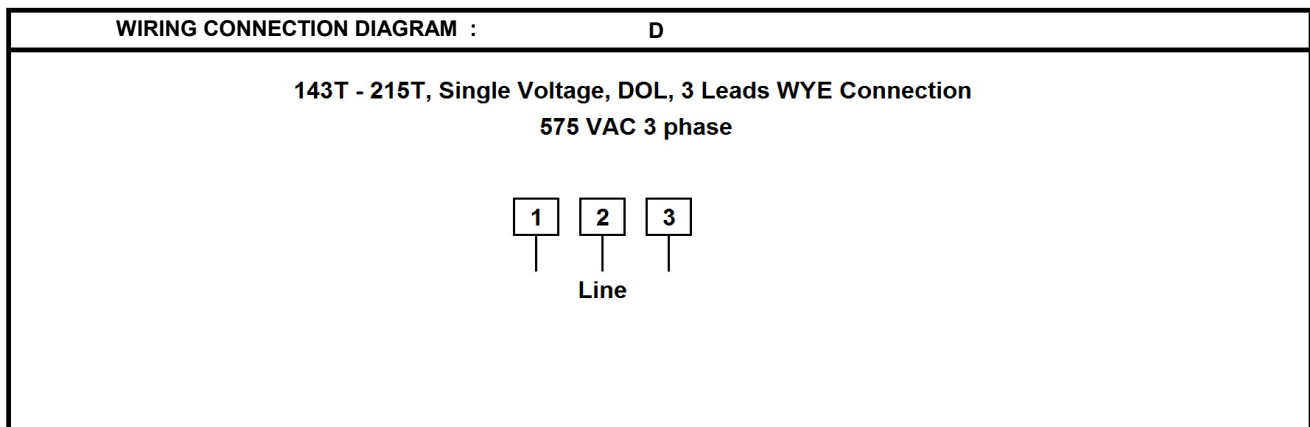

Date: 2022-08-30
 Customer: _____
 Contact: _____
 Submittee: J.C. Lavallée

Catalogue #: **JMPPS-2**

NEMA PREMIUM NR CAN NEMA 12 - 12										
HP	VAC	RPM	Enclosure	Frame	Frequency	Design	Poles	LR Code Letter	Insulation Class	Temp. Rise °C
1	575	1740	TEFC	143JM	60	B	4	K	F	25
	0Hz	6Hz	15Hz	30Hz	45Hz	60Hz	75Hz	90Hz	105Hz	120Hz
Amps	1,36	1,36	1,36	1,36	1,36	1,36	1,36	1,36	1,36	1,36
RPM	0	174	435	870	1305	1740	2175	2610	3045	3480
Torq ft.lb	2,41	2,41	3,02	3,02	3,02	3,02	2,41	2,01	1,72	1,51
Peak Tq ft.lb	3,85	7,70	7,70	7,70	7,70	7,70	6,16	5,13	4,40	3,85
HP	0	0,1	0,3	0,5	0,8	1,0	1,0	1,0	1,0	1,0
	Locked Rotor	Pull-Up	Breakdown	Rated Load	Idle	Duty	S. F.	Ambient	Elevation	dBa @ 1M
Speed (RPM)	0,0	756	1440	1740	1800	Continuous	1,15	40°C	3,300 ft	61
Current (Amps)	12,0	10,2	7,1	1,4	0,6	VFD Rating: Meets MG1 parts 31.4.4.2				
Torque (ft-lbs)	9,1	7,7	9,4	3,0	0,0	C.T.	10:1	V.T.	20:1	

Motor Speed Data

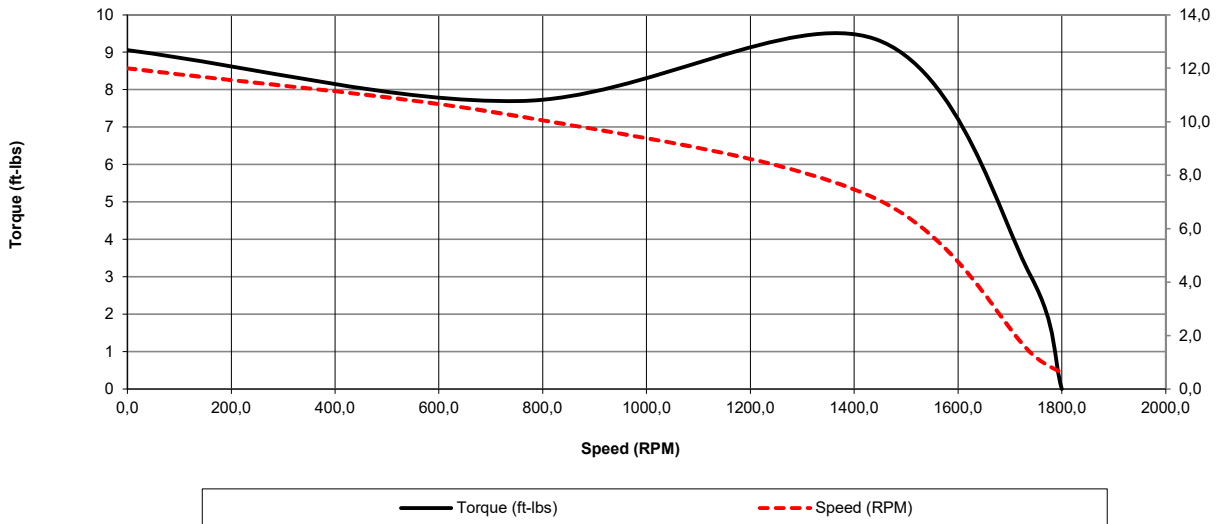

Motor Torque Capability vs RPM

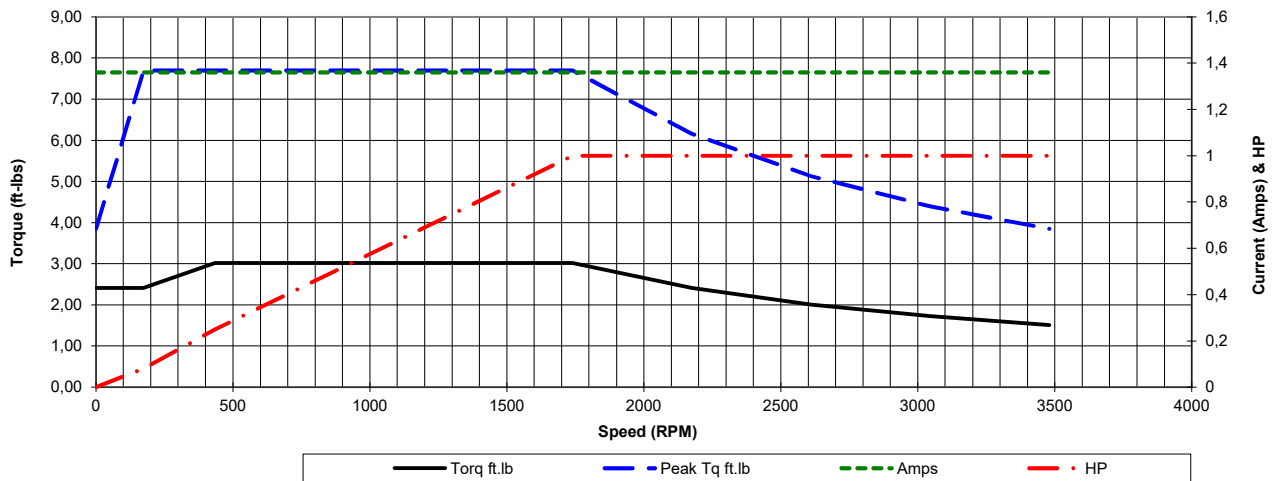

Date: 2022-08-30
 Customer: _____
 Contact: _____
 Submittee: J.C. Lavallée

Catalogue #: **JMPPS-2**

NEMA PREMIUM NR CAN NEMA 12 - 12

HP	VAC	RPM	Enclosure	Frame	Frequency	Design	Poles	LR Code Letter	Insulation Class	Temp. Rise °C
1	575	1740	TEFC	143JM	60	B	4	K	F	25

Load %	0%	25%	50%	75%	100%	125%	150%
Amps	0,61	0,64	0,83	1,07	1,36	1,67	1,99
Torq ft/lbs	0	0,74	1,48	2,24	3,02	3,81	4,61
RPM	0	1785	1770	1755	1740	1725	1710
Eff	0	65,52	78,00	84,20	85,50	85,50	85,50
PF	0	35,0	47	60	64,4	65,7	66,0

	Locked Rotor	Pull-Up	Breakdown	Rated Load	Idle	Duty	S. F.	Ambient	Elevation	dBA @ 1M
Speed (RPM)	0	756	1440	1740	1800	Continuous	1,15	40°C	3,300 ft	61
Current (Amps)	12	10,2	7,1	1,36	0,612	VFD Rating: Meets MG1 parts 31.4.4.2				
Torque (ft-lbs)	9,06	7,70	9,36	3,02	0,0	C.T.	10:1	V.T.	20:1	

Motor Speed Data

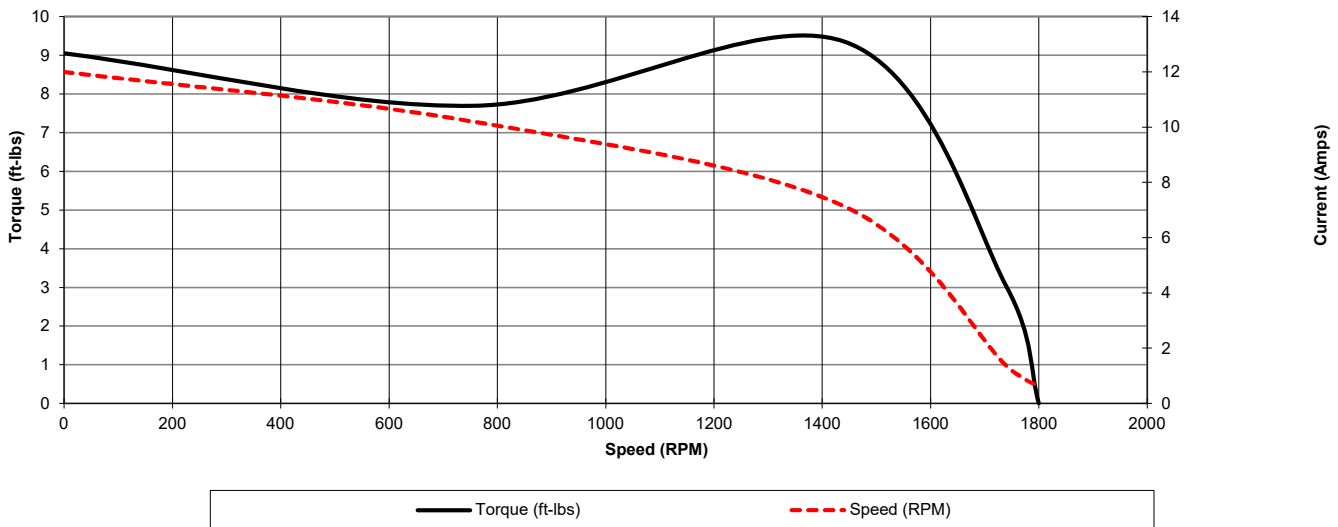

Motor Load Data

